



EBARA

	Page
- SPECIFICATIONS	200
SELECTION CHART	201
TYPE KEY	202
CURVE SPECIFICATIONS	203
PERFORMANCE CHART BEST ONE	204
PERFORMANCE CHART BEST ONE VOX	205
- CONSTRUCTIONS	300
SECTIONAL VIEW DRAWING	300
SECTIONAL VIEW TABLE	301
BEARINGS	302
MECHANICAL SEAL	303
SINGLE PHASE DIAGRAM AND ELECTRIC CONNECTIONS	304
THREE PHASE DIAGRAM AND ELECTRIC CONNECTIONS	305
- INSTALLATION	400
- DIMENSIONS AND WEIGHT	500
PUMP	500
PACKING	501
- TECHNICAL DATA	600
- OPTIONAL	700
MINIMUM SUCTION SYSTEM	700

SPECIFICATION

50Hz

Rev. L

PUMP		
Liquid Handled	Type of liquid	Clear water (Clean water for MS version)
	Max temperature [°C]	50
	Max solids size [mm]	10 20 (for Vortex version)
Maximum immersion [m]		5
Construction	Impeller	Semi-open centrifugal type (BEST ONE) Vortex type (BEST ONE VOX)
	Shaft seal type	Oil lubricated mechanical seal (pump side) + lip seal (motor side)
	Bearing	Sealed ball bearing
Pipe Connection	Suction	Strainer
	Discharge nozzle [inch]	G1¼": UNI ISO 228
Material	Pump casing	AISI 304
	Impeller	AISI 304
	Shaft seal	Mechanical seal: Ceramic/Carbon/NBR Lip seal: NBR
	Casing cover	AISI 304
	Shaft	AISI 303 + AISI 303 ceramic coated shaft sleeve
	Lubricating liquid	White mineral oil: Esso Marcol 152
Applicable standard of test		ISO 9906 – Annex A

MOTOR			
Type	Submersible dry type		
	Single Phase	Three Phase	
No. of Poles	2		
Rotation speed [min ⁻¹]	≈2800		
Insulation Class	F		
Protection degree	IP 68		
Power rating	[kW]	0.25	
	[HP]	0.33	
Frequency [Hz]	50		
Voltage [V]	230 ±10%	400 ±10%	
Capacitor	Built in	-	
Over load protection	Built in	-	
Casing material	AISI 304		
Switch	float	MA version (no maintenance required)	
	magnetic	MS version (maintenance required)	
Float/magnetic switch cable	material	H07RN-F	
	size	3G1	
Power cable	length [m]	5 (only for internal usage)	
	material	H05RN-F	H07RN-F
	size	3G0.75	4G1
Cable entry	Cable Gland		

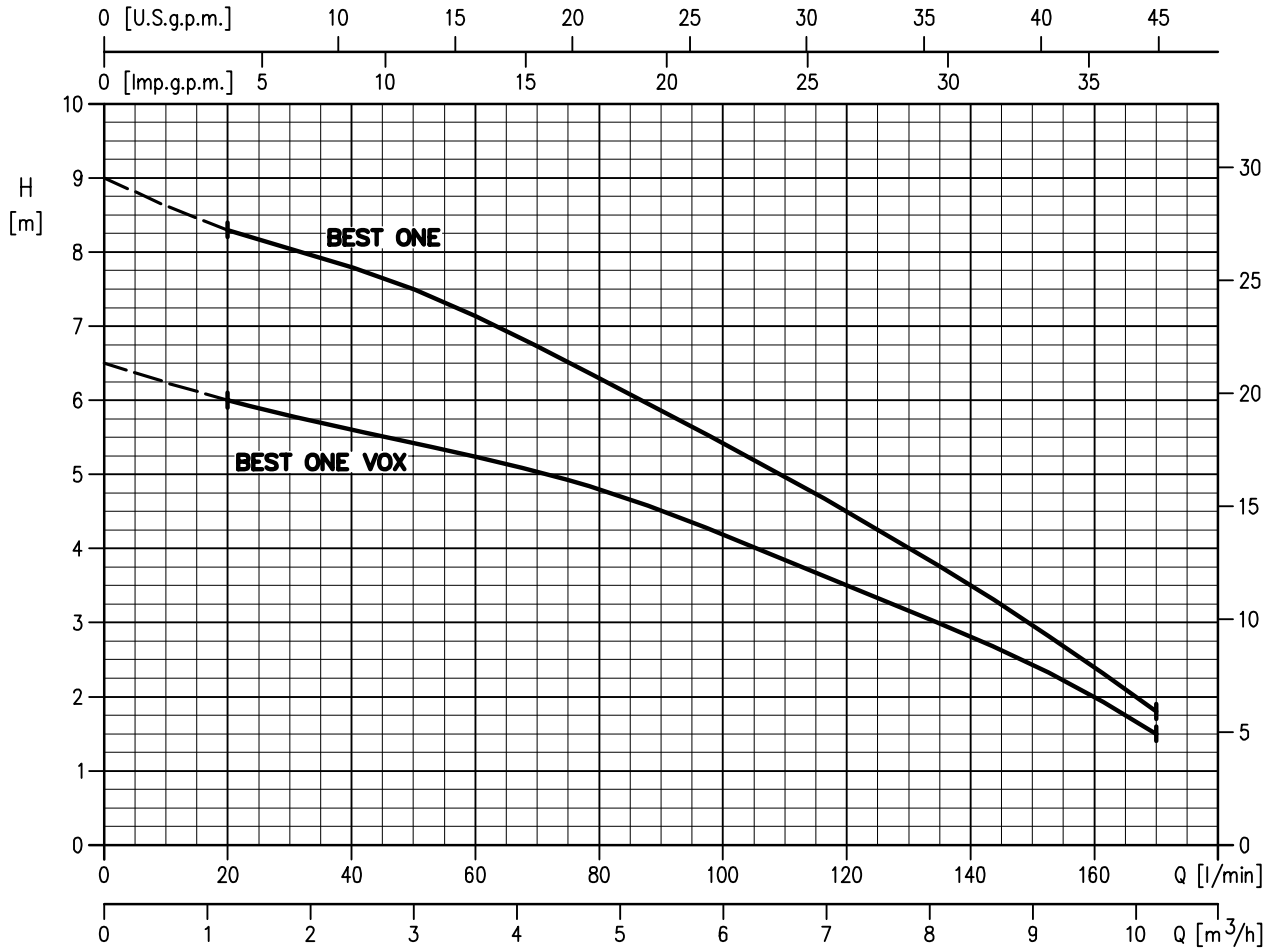

Type pumps		Power		Q=Capacity						
Single Phase	Three Phase	kW	HP	l/min	20	40	80	120	160	170
				m³/h	0	1,2	2,4	4,8	7,2	9,6
H=Total manometric head in meters										
BEST ONE M	BEST ONE	0,25	0,33	9,0	8,3	7,8	6,3	4,5	2,4	1,8
BEST ONE VOX M	BEST ONE VOX	0,25	0,33	6,5	6,0	5,6	4,8	3,5	2,0	1,5

TYPE KEY

50Hz

Rev. L

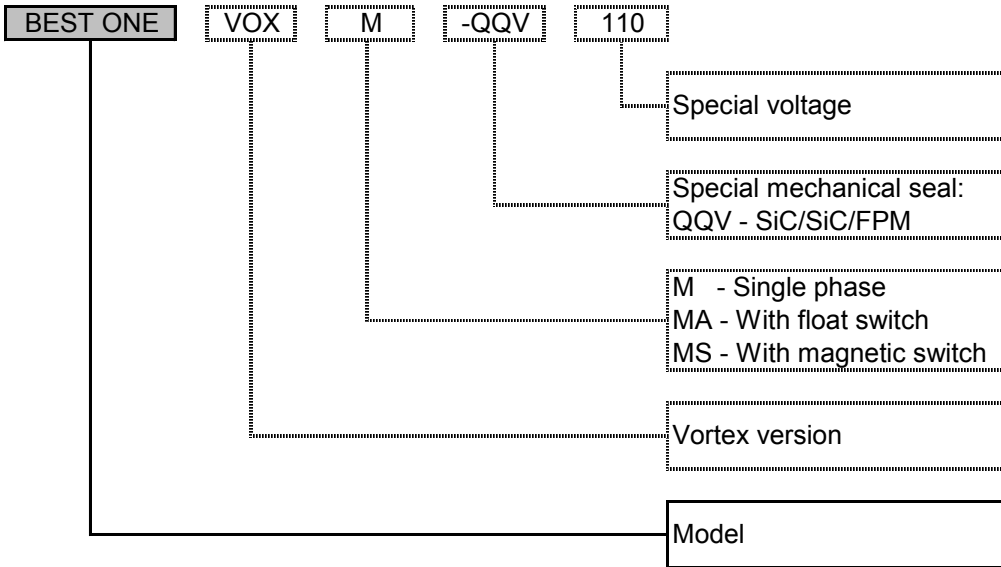

Curve specifications

The specifications below qualify the curves shown on the following pages.

Tolerances according to ISO 9906 Annex A

The curves refer to effective speed of asynchronous motors at 50 Hz

Measurements were carried out with clean water at 20°C of temperature and with a kinematic viscosity of $\nu = 1 \text{ mm}^2/\text{s}$ (1 cSt)

In order to avoid the risk of over-heating, the pumps should not be used at a flow rate below 10% of best efficiency point.

Symbols explanation:

Q = volume flow rate

H = total head

BEST ONE

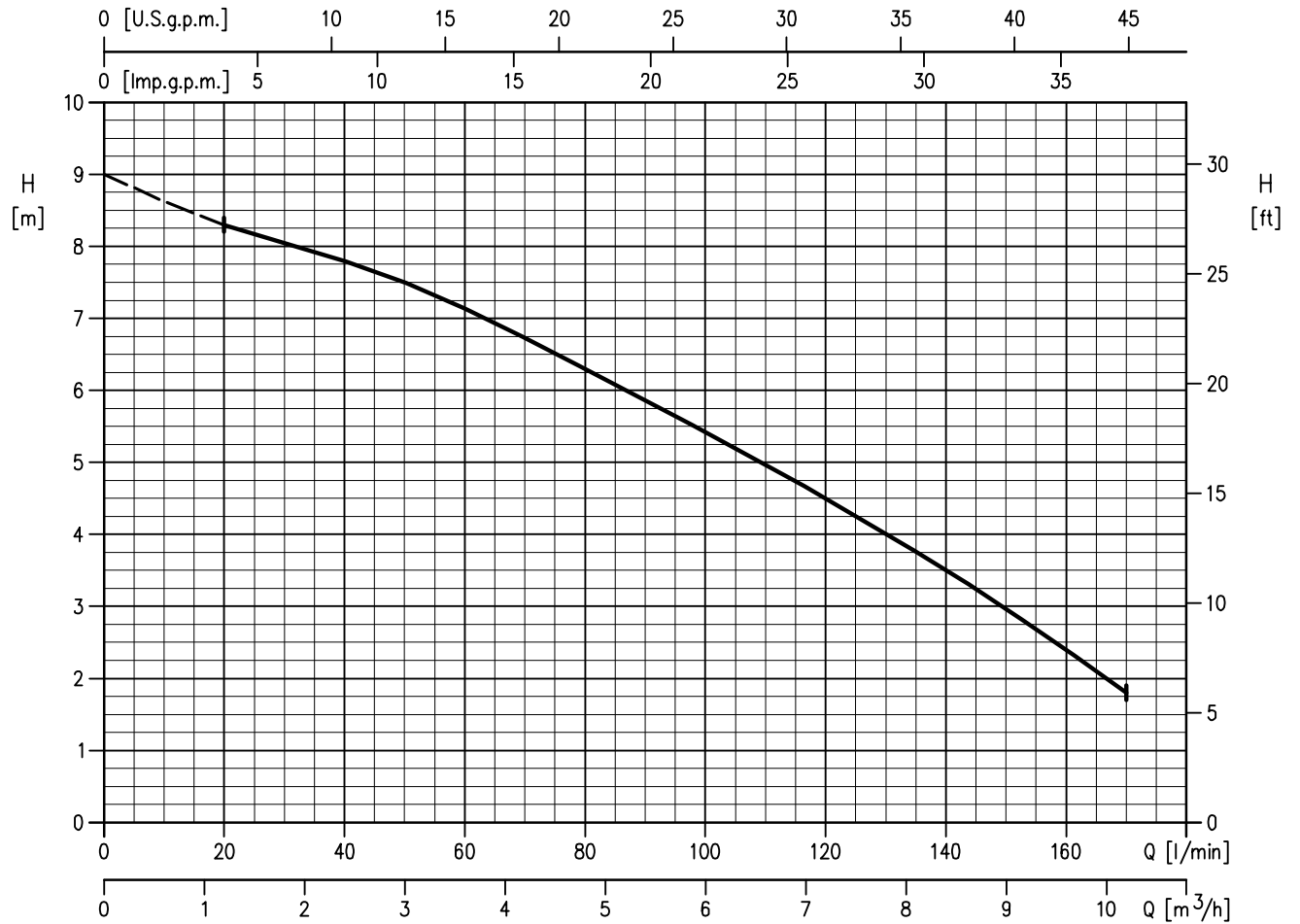

BEST ONE VOX

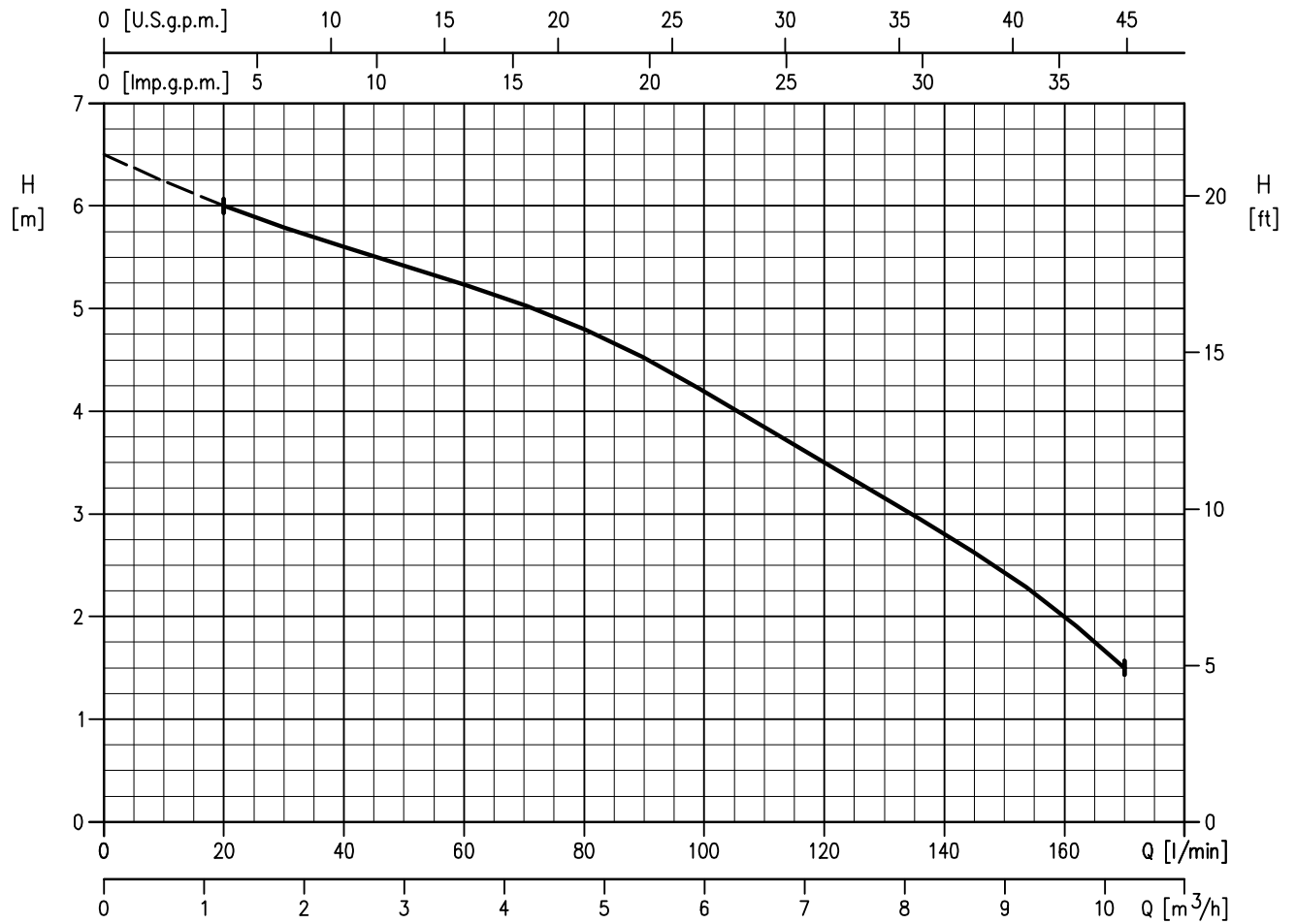

SECTIONAL VIEW

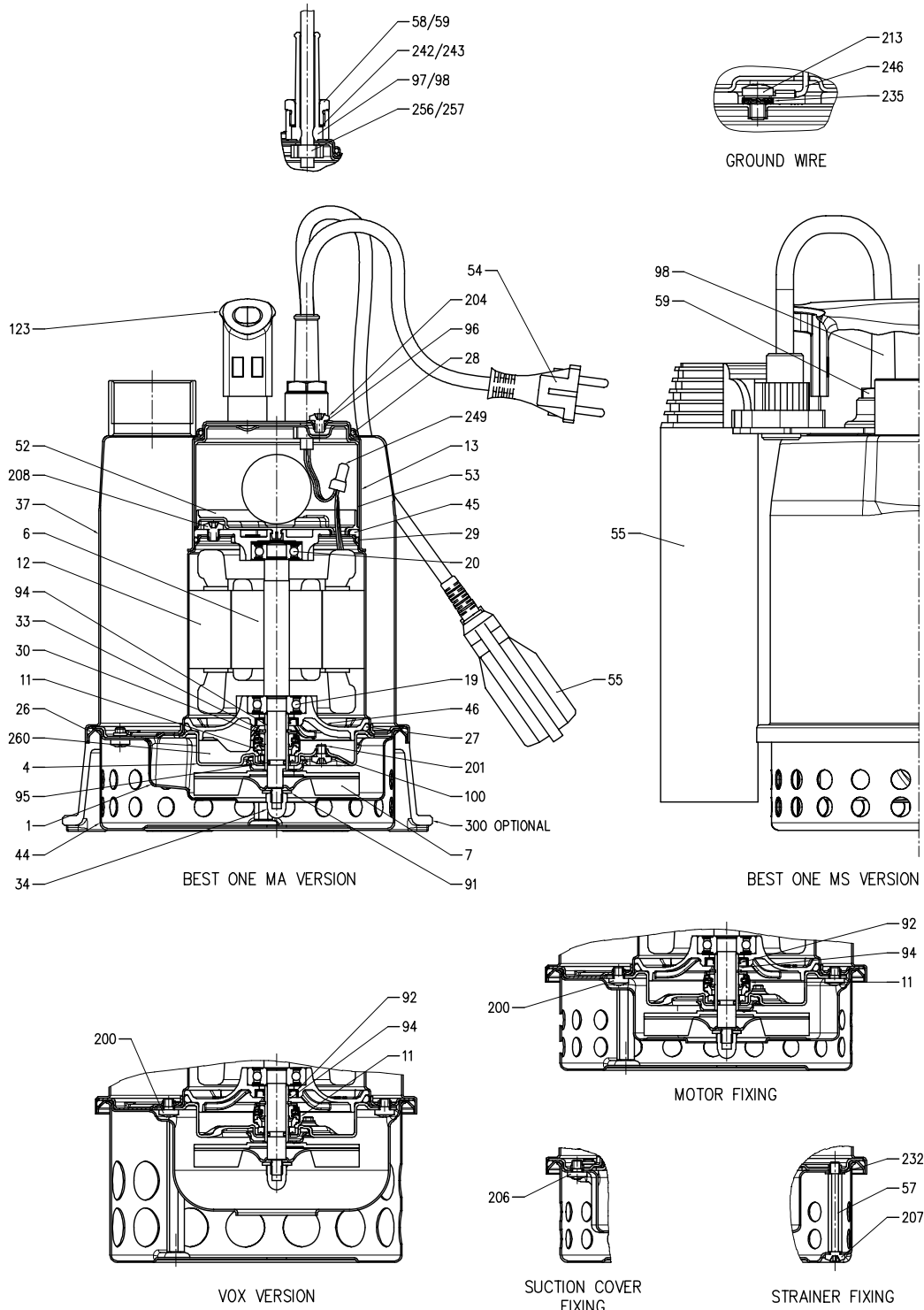

SECTIONAL VIEW TABLE

Rev. L

N°	PART NAME	MATERIAL	DIMENSIONS	STANDARD	Q.ty
1	Suction cover	EN 1.4301 (AISI 304)	-	-	1
4	Casing cover	EN 1.4301 (AISI 304)	-	-	1
6	Shaft with rotor	EN 1.4305 (AISI 303)	-	-	1
7	Impeller	EN 1.4301 (AISI 304)	-	-	1
11	Mechanical seal [1]	[1]	[1]	-	1
12	Motor frame with stator	EN 1.4301 (AISI 304)	-	-	1
13	Motor cover	EN 1.4301 (AISI 304)	-	-	1
19	Lower ball bearing	-	-	-	1
20	Upper ball bearing	-	-	-	1
21	Adjusting ring	-	-	-	1
23	Capacitor [2]	-	-	-	1
26	O-ring	NBR	159,5x3	-	1
27	O-ring	NBR	88,5x3,53	-	1
28	O-ring	NBR	75,87x2,62	-	1
29	O-ring	NBR	75,87x2,62	-	1
30	Washer	EN 1.4301 (AISI 304)	12x21x1	-	1
33	Seeger ring	Carbon steel TC80	12	UNI 7435	1
34	Impeller nut	A2 - 70 UNI 7323	M6	UNI 5721	1
37	Pump casing	EN 1.4301 (AISI 304)	-	-	1
44	Strainer	EN 1.4301 (AISI 304)	-	-	1
45	Upper bearing housing	EN 1706 AC-46000 D	-	-	1
46	Lower bearing housing	EN 1706 AC-46000 D	-	-	1
52	Terminal insulating base	PA6	-	-	1
53	Terminal insulating box	PA6	-	-	1
54	Power cable	-	-	-	1
55	Switch [3] [4]	-	-	-	1
57	Spacer	EN 1.4301 (AISI 304)	-	-	2
58	Power cable connector	OT 58 UNI 5705-65 Nickel-plated Brass	-	-	1
59	Switch cable connector [3]	OT 58 UNI 5705-65 Nickel-plated Brass	-	-	1
91	Washer	EN 1.4301 (AISI 304)	-	-	1
92	Lip seal	NBR	22x12x4	-	1
94	Shaft sleeve	EN 1.4305 (AISI 303) ceramic coated	-	-	1
95	O-ring	NBR	6,07x1,78	-	1
96	O-ring	NBR	4,48x1,78	-	1
97	Power cable connector	NBR	-	-	1
98	Switch cable connector [3]	NBR	-	-	1
100	O-ring	NBR	4,48x1,78	-	1
123	Handle	PP	-	-	1
200	Screw	A2 - 70 UNI 7323	M5x6	UNI 7687	4
201	Screw	A2 - 70 UNI 7323	M5x6	UNI 7687	1
204	Screw	A2 - 70 UNI 7323	M5x6	UNI 7687	1
206	Screw	A2 - 70 UNI 7323	M5x6	UNI 7687	3
207	Screw	A2 - 70 UNI 7323	M5x6	UNI 7687	2
208	Screw	A2 - 70 UNI 7323	M5x6	UNI 7687	3
213	Screw	A2 - 70 UNI 7323	M4x6	UNI 7687	1
232	Washer	PA6	5,5x10x1	-	1
235	Washer	Zinked Steel	4	UNI 8842	1
242	Washer	EN 1.4301 (AISI 304)	13,4x15,9x1	-	1
243	Washer [3]	EN 1.4301 (AISI 304)	13,4x15,9x1	-	1
246	Ground wire	-	-	-	1
256	Strain relief	-	-	-	1
257	Strain relief [3]	-	-	-	1
260	Oil	Esso Marcol 152	-	-	40 cc
300	Minimum suction system [5]	Thermoplastic elastomer vulcanizate	-	-	-

[1] See pag. 303

[2] Only for single phase

[3] Only for automatic version

[4] It could be floating or magnetic type

[5] OPTIONAL See pag.700

BEARINGS

Type pumps		Ball Bearing	
Single Phase	Three Phase	Lower side	Upper side
BEST ONE M	BEST ONE	6200 ZZ C3	6000 ZZ C3

MECHANICAL SEAL

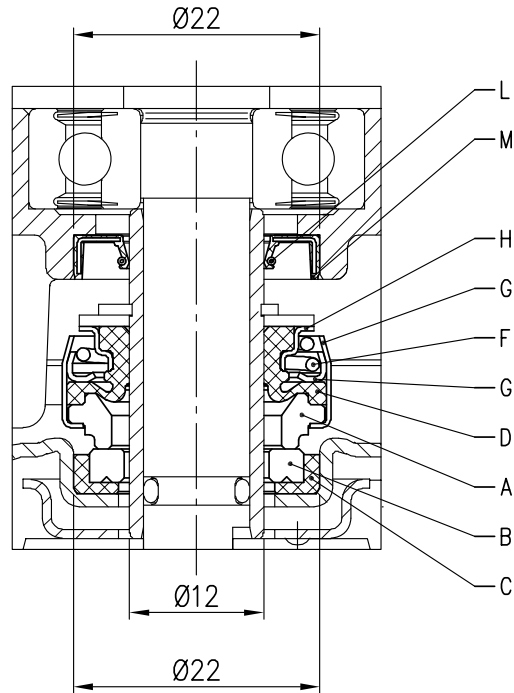

REF	PART NAME	MATERIAL product standard	MATERIAL optional
A	Rotary seal ring	Carbon graphite	SiC
B	Stationary seal ring	Ceramic	SiC - Q6 (*)
C	Gasket	NBR	FPM
D	Bellows	NBR	FPM
F	Self driving spring	EN 1.4301 (AISI 304)	
G	Frame	EN 1.4301 (AISI 304)	
H	Retainer ring	EN 1.4301 (AISI 304)	
L	Spring	EN 1.4318 (AISI 302)	
M	Lip	NBR	

(*) Special grade of SiC with microporosities filled with graphite

SINGLE PHASE MOTOR DIAGRAM AND ELECTRIC CONNECTIONS

WITHOUT FLOAT SWITCH

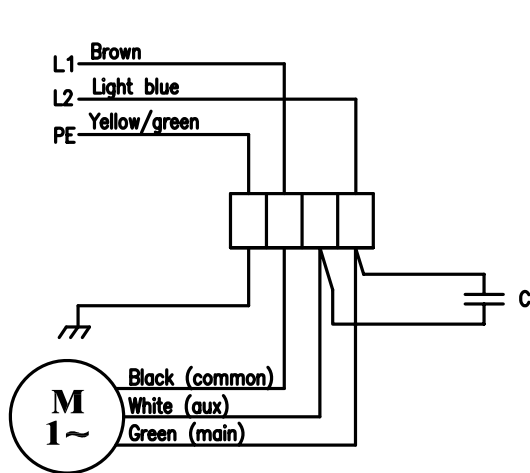

WITH FLOAT SWITCH

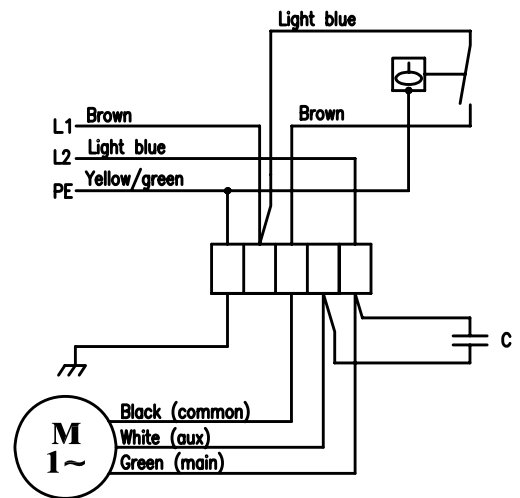

230 V
INTERNAL MOTORPROTECTOR

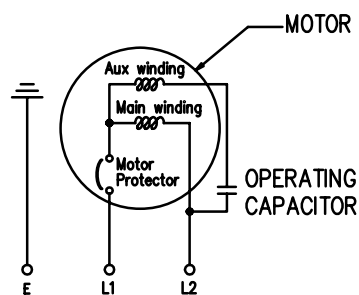

TREE PHASE MOTOR DIAGRAM AND ELECTRIC CONNECTIONS

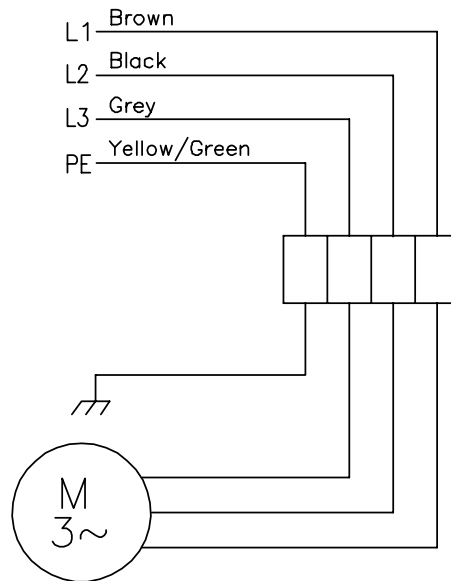

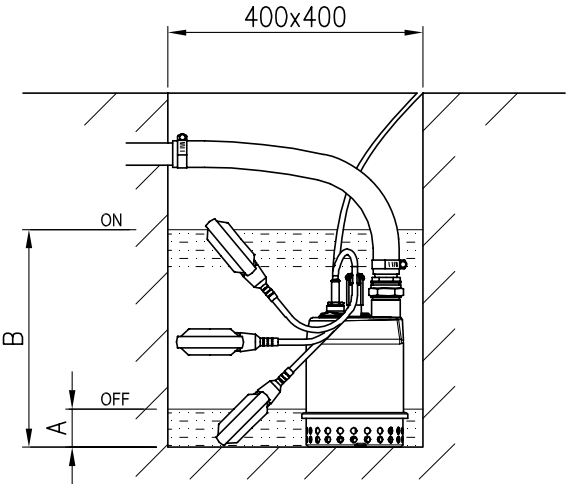
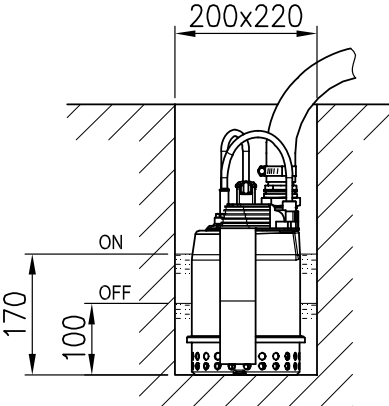
BEST ONE MA/ONE VOX MA	BEST ONE MS									
										
<table border="1" style="margin: auto; border-collapse: collapse;"> <thead> <tr> <th style="padding: 5px;">Pump</th> <th style="padding: 5px;">A</th> <th style="padding: 5px;">B</th> </tr> </thead> <tbody> <tr> <td style="padding: 5px;">BEST ONE MA</td> <td style="padding: 5px;">60</td> <td style="padding: 5px;">340</td> </tr> <tr> <td style="padding: 5px;">BEST ONE VOX MA</td> <td style="padding: 5px;">90</td> <td style="padding: 5px;">370</td> </tr> </tbody> </table>		Pump	A	B	BEST ONE MA	60	340	BEST ONE VOX MA	90	370
Pump	A	B								
BEST ONE MA	60	340								
BEST ONE VOX MA	90	370								

PUMP

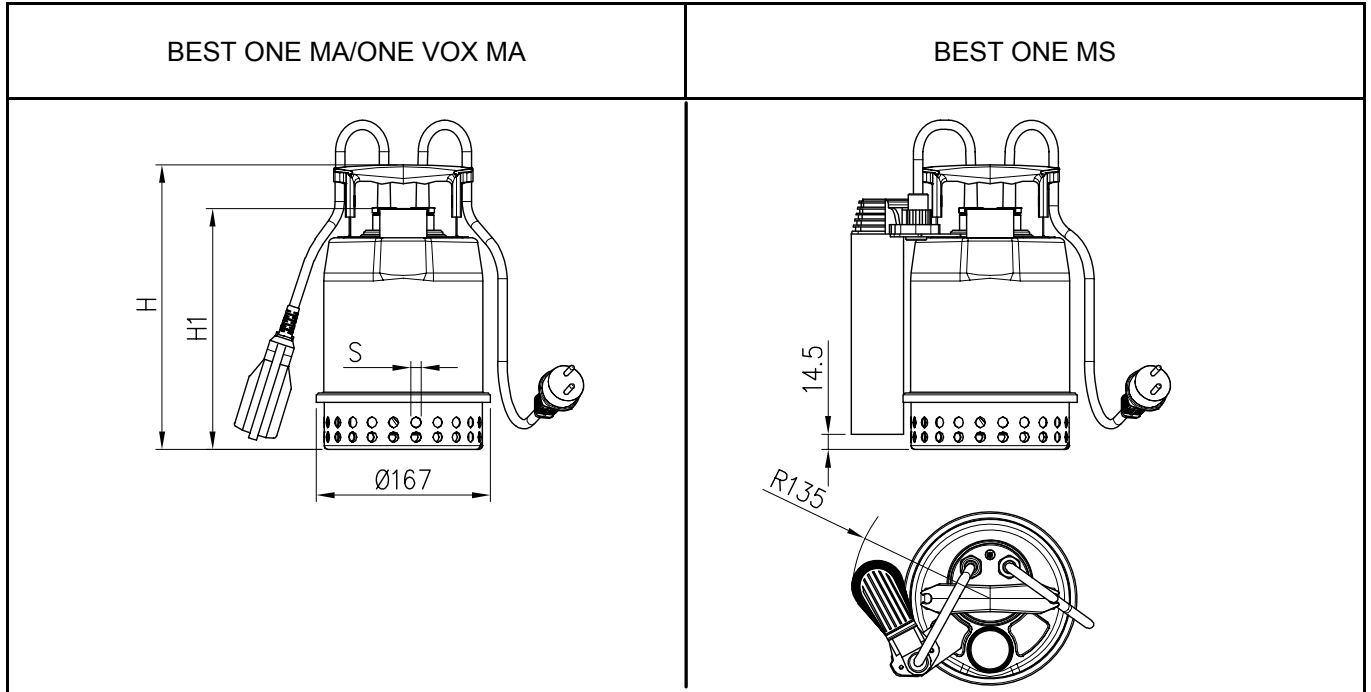

Type Pumps	Dimensions [mm]			Weight [kgf]
	H	H1	S	
BEST ONE	273	231	10	4.3
BEST ONE M				4.4
BEST ONE MA				4.6
BEST ONE MS				4.8
BEST ONE VOX	304	262	20	4.4
BEST ONE VOX M				4.5
BEST ONE VOX MA				4.7

PACKING

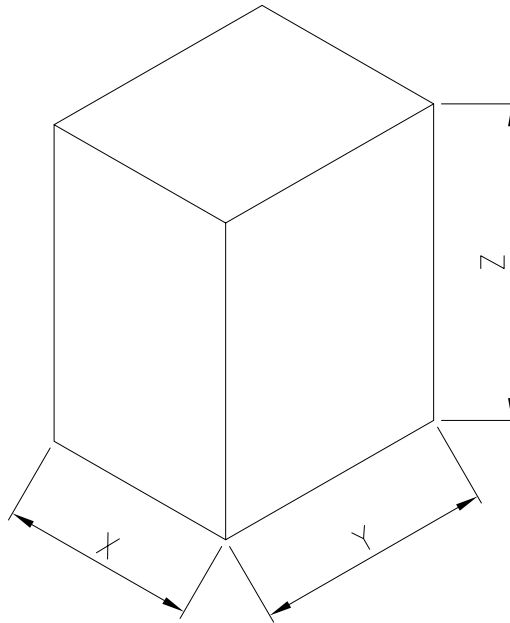

Type Pumps	Dimensions [mm]			Weight [kgf]
	X	Y	Z	
BEST ONE	180	220	330	4.8
BEST ONE M				4.9
BEST ONE MA				5.1
BEST ONE MS				5.3
BEST ONE VOX				4.9
BEST ONE VOX M				5.0
BEST ONE VOX MA				5.2

ELECTRIC DATA											
Type pumps		kW	HP	Capacitor Single Phase		Input [kW]		Full load current [A]		Locked rotor current	
Single Phase	Three Phase			μF	Vc [V]	Single Phase	Three Phase	Single Phase 230 V	Three Phase 400 V	Single Phase 230 V	Three Phase 400 V
Best One M	Best One	0,25	0,33	8	450	0,51	0,47	2,3	0,8	5,8	2,7
Best One Vox M	Best One Vox	0,25	0,33	8	450	0,50	0,44	2,2	0,8	5,6	2,7

MINIMUM SUCTION SYSTEM

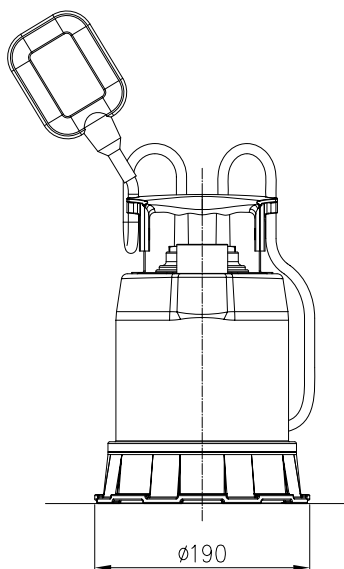

LEVEL	
Minimum starting suction level	10 mm
Minimum suction level capability	3 mm

COMPATIBILITY				
Type pumps	Version			
	1~			3~
	M	MA	MS	
Best One	✓	✓	✗	✓
Best One Vox	✗	✗	✗	✗